

On the New Branch of Mathematical Science

¹M. Sivasubramanian and ²S.Kalimuthu

¹Department of Mathematics, Mahalingam College of Engineering and Technology,
Pollachi Via, Tamilnadu-642003, India

²Kanjampatti P.O, Pollachi Via, Tamilnadu-642003, India

Abstract: The origin of geometry dates back 30000(Thirty thousand years) B.C^[3]. Euclid of Alexandria (2300 B.C.) compiled the Elements which is the first scientific text book. Euclid assumed five postulates. There is no proof for the fifth postulate. Almost all the celebrated mathematicians tried their best to deduce this from the first four postulates. But unfortunately, nobody was successful. Saccheri and Lambert worked on this problem for more than 50 years. The authors start where Saccheri and Lambert failed to obtain the following result/theorem. In a Lambert quadrilateral the fourth angle is the right angle or the lateral sides of a Lambert quadrilateral are equal. This proposition was proved by proof by contradiction.

Keywords: Euclid, elements, postulates and Non-Euclidean geometries

INTRODUCTION

The word geometry was derived from two Greek words geo meaning earth and metric meaning measuring. Euclid of Alexandria wrote his first scientific text book Elements. The Element assumes the following postulates^[4]:

- A straight line may be drawn between any two points
- A piece of straight line may be extended indefinitely
- A circle may be drawn with any given radius and an arbitrary center
- All right angles are equal
- If a straight line crossing two straight lines makes the interior angles on the same side less than two right angles, the two straight lines, if extended indefinitely, meet on that side on which are the angles less than two right angles

After Euclid, many mathematicians tried their best to prove the above mentioned fifth postulate. But nobody could succeed. The authors attempt to deduce the fifth Euclidean postulate from the first four axioms.

MATERIALS AND METHODS

In this study, we begin where Saccheri and Lambert missed to achieve the result. In further studies, the

application of number theory, matrix algebra and set theory may be used.

RESULTS

Let ABCD is the Lambert quadrilateral^[2] where the angles at A, B and C are right angles as shown in Fig. 1.

Case 1: Let CD is smaller than AB. On the extension of CD, cut off CE such that CE = AB. Join A and E. Now ABCE is a Saccheri quadrilateral^[1,2,4]. The summit angles of Saccheri quadrilateral are equal. Since angle BAE is obtuse, we get that angle CEA is obtuse.

Erect EF perpendicular to ED. Angle DEF is 90°. From 1 and 2 we get a contradiction. This shows that case 1 is not possible.

Case 2: Let CD is greater than AB. On CD, cut off CH such that CH = AB. Join A and H. Now ABCH is a Saccheri quadrilateral. So, angles BAH and CHA are equal. Since angle BAH is acute, we get the angle CHA is also acute.

Construct HJ perpendicular to HC. Now the angle CHJ is 90°.

From 3 and 4 we get a contradiction. This proves that case 2 is also not acceptable.

From cases 1 and 2, we get that AB = CD.

If AB = CD, then the angle at D is 90°.

Corresponding Author: M. Sivasubramanian, Department of Mathematics,
Mahalingam College of Engineering and Technology, Pollachi Via, Tamilnadu-642003, India

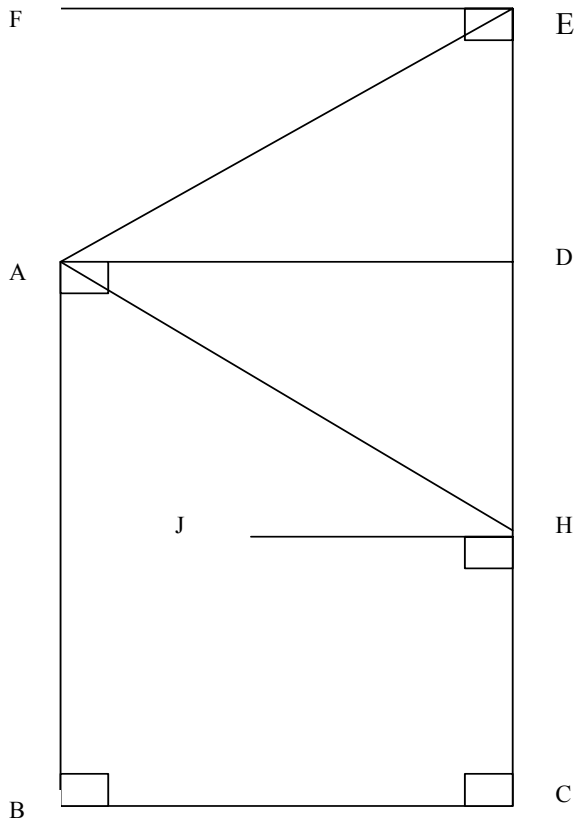

Fig. 1: Euclidean

DISCUSSION

We have derived Eq. 5 without assuming the fifth Euclidean postulate. This proves the parallel postulate^[1, 2]. But the mere existence of consistent models of Non-Euclidean geometries demonstrate that Euclid’s 5th postulate is a special case. So, this is a serious and curious problem. Further studies will reveal a new field of mathematical science.

CONCLUSION

Labachevsky, the noted Russian mathematician, was the first person in the history of mathematics to formulate a model of non-Euclidean geometry which is also known as hyperbolic geometry. The formulae of this branch of geometry are widely used to study the properties of atomic objects in quantum physics. Also, the celebrated German mathematicians Gauss and Riemann developed the second branch of non-Euclidean geometry whose another name is elliptic geometry. Einstein by using the concepts of Riemannian geometry nearly took 10 years to formulate his general theory of relativity. The authors do not make any top claim but politely state that their result is consistent. There is a hidden treasure. Further studies will definitely unlock this problematic problem and definitely give birth to a new branch of mathematics. A turning point in geometry is also a mile stone in physics. Modern physics is facing many odds. The new future field will solve some physical problems such as monopoles, quantum gravity, the dual property of electrons of an atom, antimatter, dark matter, shadow of matter, gravitons and black holes.

ACKNOWLEDGEMENT

The authors wish to thank the late professor P. Kaliappan and the management of Nallamuthu Gounder Mahalingam College, Pollachi, Tamilnadu-642001, India for their kind encouragement.

REFERENCES

1. www.groups.dcs.standac.uk/~history/HisTopics/Non.Euclidean_geometry.
2. www.cut-the-knot.org.
3. <http://www.softsurfer.com/history.html>.
4. www.beva.org/math323/asgn6/nov19.htm.