

## Supplying a Common Distribution Load through Two Different Sources

Naeem M.H. and K.P. Basu  
Multimedia University, 63100 Cyberjaya, Malaysia

---

**Abstract:** Phase angle difference between any two busbar voltages of a big power system varies with the loading and operating condition of the power system. Supplying a common distribution load from these two phase shifted sources needs the application of a controlled phase shifter. Three-phase tapped autotransformer connected in delta with properly controlled variation of input and output tap settings may perform the function of this type of phase shifter. Both on-load and off-load tap changing may be used to control the phase angle for scheduled sharing of a common distribution load between these two phase shifted sources. Independent control of voltage magnitude is also possible through the same phase shifter.

**Key words:** Power distribution, static phase shifter, tap changing transformer, power flow controller

---

### INTRODUCTION

Many times distribution loads connected to a common busbar are supplied by a distribution transformer getting its supply from a single extra high voltage transmission line. Initially the ratings of the line and the transformer are sufficient not only to carry the full load but also to cater for the growth of the load in the near future. With the passing of time the load growth may surpass the rating of the existing transmission line and/or the transformer. The addition of a new line and/or a second transformer becomes a necessity. In many power systems another distribution substation may be situated in close proximity. Interconnection of these two substations by a short distribution line may provide a low cost solution to this problem. The nearby substation may cater a part of the load of the first substation.

Sharing of load according to a specified proportion between the substations depends upon the phase difference and magnitude ratio of the two busbar voltages.

This study proposes the application and control of a new type of static phase shifter (SPS) or phase angle regulator (PAR) for proper sharing of load between the substations having a variable phase difference between their voltages. Detail analysis and implementation of the scheme has also been presented.

**Problem formulation:** Figure 1 shows a big power system. A 132/11kV transformer supplies the 11kV bus1 of the distribution substation and the load on this substation has been grown up to a value more than the rating of the 132kV line and/or the transformer. Another 11kV distribution substation (bus2) is situated nearby. It is proposed to connect the two busbars through a short 11kV distribution line DL (shown by dotted line in Fig. 1), such that a part of the load at bus1

may be supplied from bus2 through the short distribution line. Voltage magnitudes  $|V_1|$  and  $|V_2|$  at buses 1 and 2 are generally kept constant to 11kV by controlling the tap changers of 132kV and 220kV transformers. But a phase angle difference of  $\Phi$  always exists between  $V_1$  and  $V_2$ . This phase difference depends basically on the operating and loading conditions of the big power system and is almost independent of the loading of the two distribution substations. It is to be noted that the combined load on the buses 1 and 2 is insignificant in comparison to the total load of the big power system. The chronological load variation of the power system creates phase difference, changing with time between the 132kV and 220kV buses. Specified values of real and reactive power, which are fractions of total load power at bus1, may be allowed to flow through DL by maintaining a constant phase difference and voltage magnitude ratio between the two buses.

A back-to-back dc link<sup>[1,2]</sup> between the buses 1 and 2 may be used to transfer the specified amount of real power from bus2 to bus1. Unified power flow controller (UPFC)<sup>[3,4]</sup> may also claim its application to transfer the desired real and reactive power flow from bus2 to bus1. However, very high cost and production of harmonics in both the cases restricts their use.

A properly designed static phase shifter (SPS), described later, connected between buses2 and 3 may perform this function at a lower cost without producing any harmonics. As the angle  $\Phi$  between the two buses is changing with the operating and loading conditions of the power system, the phase angle regulator should be able to adjust its phase angle in such a way so as to keep the phase difference between buses 1 and 3 to be constant. The voltage magnitude ratio  $|V_3|/|V_1|$  controls the reactive power flow through the short distribution line.

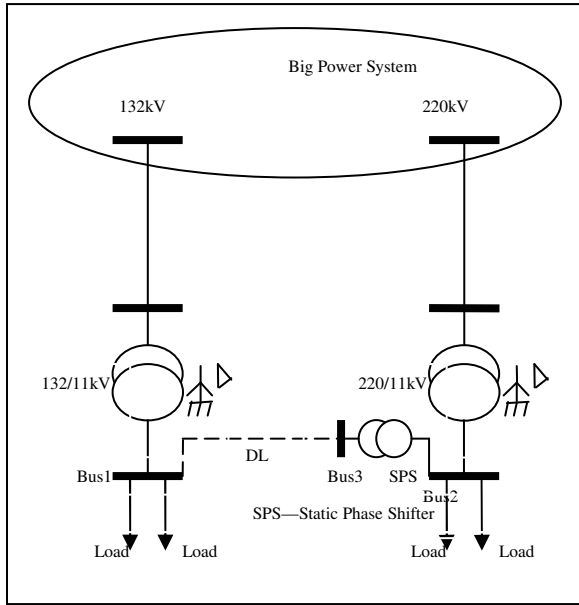

Fig.1: Distribution system

**Mathematical analysis:** The equivalent circuit of the distribution system is shown in Fig. 2.  $G_1$  and  $G_2$  represent the equivalent source voltages at buses 1 and 2, respectively. Phase difference  $\Phi$  solely depends upon the operating and loading conditions of the big power system and is independent on the loading of bus 1 and 2.  $|V_1|$  and  $|V_2|$  may be kept constant and equal to the nominal voltage by adjusting the online tap changers of the 132kV and 220kV transformers shown in Fig. 1. The phase shifting transformer connected between buses 2 and 3 provides a phase shift of  $\angle \beta = \angle(\delta - \Phi)$  and a voltage magnitude ratio of  $k = |V_3|/|V_1|$ , where  $\delta$  is the voltage angle of bus3. Both  $\beta$  and  $k$  may be controlled independently. The total reactance between buses 1 and 2 is represented by  $jX$ . Resistance is neglected.  $jX = j(X_l + X_d + X_e)$ . Where,  $X_l$ =leakage reactance of the phase shifting transformer,  $X_d$ =reactance of the short distribution line and  $X_e$ =external reactance in series with the phase shifter.

$P$  and  $Q$  are the real and reactive powers received by bus1 through the distribution line DL and are fractions of the total load power of bus1.

$$P = V_1 V_3 \sin \delta / X \quad (1)$$

$$Q = V_1 V_3 \cos \delta / X - V_1^2 / X \quad (2)$$

The received apparent power  $S = \{(P^2 + Q^2)^{1/2}\}$  restricts overloading of the 132kV transformer and the line. To maximize the loading of the 132kV transformer and the line the load power factor of bus1 is generally kept close to unity by adequate VAR compensation. So,  $Q \cong 0$ .

$$\text{From the equation (2), } k = \sec \delta \quad (3)$$

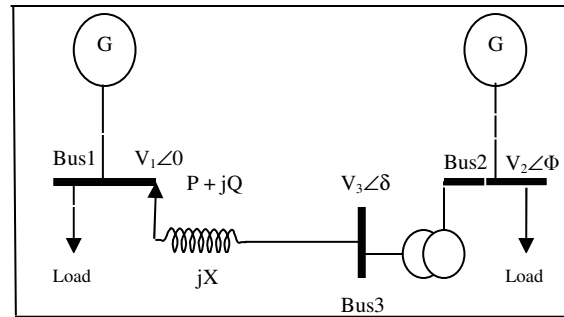

Fig. 2: Equivalent circuit

Generally  $V_1$  and  $V_2$  are controlled to be equal to 11kV (1 p.u.).

$$\text{Therefore, } \delta \cong \tan^{-1}(PX) \quad (4)$$

$$\beta \cong \tan^{-1}(PX) - \Phi \quad (5)$$

**Static phase shifter (SPS):** Many types of static and mechanical phase shifters<sup>[5-7]</sup> have been reported in the literature. Most of the SPS utilizes the principle of injecting a controlled voltage, variable in phase, in series with the phase voltage. The output of the SPS is generally used to control the loop power flow, improvement of transient stability and damping of power oscillations in transmission lines.

Conventional phase shifters use either induction regulator construction or autotransformer having tapings at the output terminals<sup>[8]</sup>. The former draws high value of exciting current and produces high retarding torque when carrying current and both of them are not acceptable. In the later<sup>[8]</sup>, the output voltage magnitude also changes with the phase angle and independent control of phase angle and voltage magnitude is not possible.

Another type of phase shifter utilizing a 3-phase variable autotransformer<sup>[9]</sup> connected in delta reported earlier. It produces phase angle variation with constant output voltage.

The application of a modified delta connected tapped autotransformer, with both the phase angle and output voltage variation facility, is presented below as the new type of phase shifter for the purpose of controlling real and reactive power flow.

Figure 3 shows a 3-phase autotransformer connected in delta. Each winding of the autotransformer has a number of tapings. The 3-phase input supply is connected across one set of tapings and the 3-phase output voltage is obtained from another set of tapings. The no-load phasor diagram is shown in Fig. 4.  $V_{ai}$ ,  $V_{bi}$ ,  $V_{ci}$  and  $V_{ao}$ ,  $V_{bo}$ ,  $V_{co}$  depict the input and output voltage phasor sets, respectively.

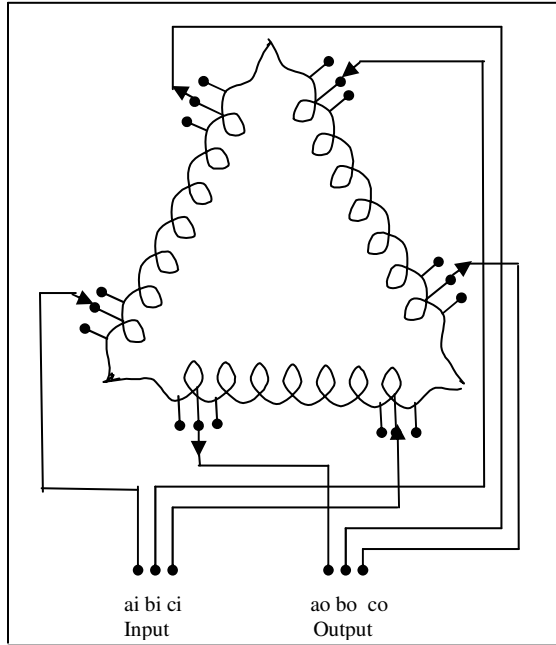

Fig. 3: Delta connected tapped autotransformer

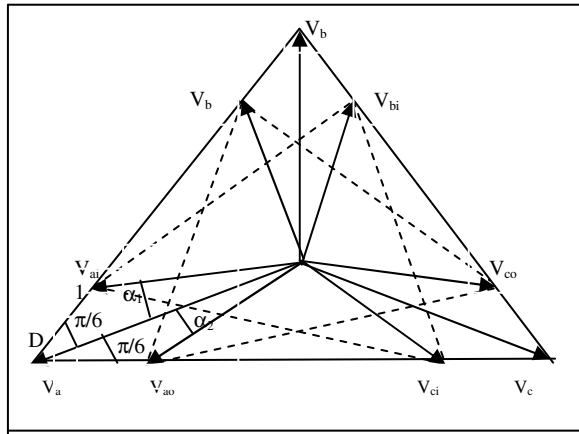

Fig. 4: No-load phasor diagram

The input taping set ai-bi-ci can be moved to either clockwise or anticlockwise direction. Similarly the output taping set ao-bo-co can be moved in the same way. The 3-phase balanced voltage set of  $V_{ai}, V_{bi}, V_{ci}$  produces a balanced voltage set of  $V_a, V_b, V_c$  at the corners of the delta winding and a balanced output voltage set of  $V_{ao}, V_{bo}, V_{co}$  is obtained. From the phasor diagram of Fig. 4 it is evident that the output voltage  $V_{ao}, V_{bo}, V_{co}$  is leading the input voltage  $V_{ai}, V_{bi}, V_{ci}$  by an angle  $\beta = (\alpha_1 + \alpha_2)$ . Interchanging of input and output terminals produces a lagging angle. From the Fig. 4 it is evident that:

$$|V_a|/|V_{ai}| = \sin(\pi/6 + \alpha_1)/\sin(\pi/6) \quad (6)$$

$$\text{And } |V_{ao}|/|V_a| = \sin(\pi/6)/\sin(\pi/6 + \alpha_2) \quad (7)$$

Therefore,

$$|V_{ao}|/|V_{ai}| = \sin(\pi/6 + \beta - \alpha_2)/\sin(\pi/6 + \alpha_2). \quad (8)$$

$$\text{For } \alpha_1 = \alpha_2, \text{ that is for } \beta = 2\alpha_1, |V_{ao}| = |V_{ai}|. \quad (9)$$

$$\text{And } \alpha_1 = \cot^{-1} [(2N/n - 3)/\sqrt{3}]$$

Where, N=total number of turns in each winding.  
And n=number of turns from the corner D to the taping point 1.

Therefore,  $\alpha_1$  and  $\alpha_2$  can be adjusted by varying the number of turns n (taping points). The ratio of output to input voltage depends upon the ratio of  $\alpha_1/\alpha_2$  that is on the relative tap settings of input and output voltages. The voltage across each winding is;

$$|V| = \sqrt{3}|V_a| = 2\sqrt{3} \sin(\pi/6 + \alpha_1)|V_{ai}| \quad (10)$$

Analysis of the next section suggests that the phase shifter is to be used for a maximum value of  $\delta \leq 15^\circ$ .

Therefore,  $|V| \leq 1.218\sqrt{3}|V_{ai}|$ ; Thus the voltage rating of each winding of the delta connected phase shifter for a supply voltage of 11kV is 13.4kV. Equation (9) suggests that a phase angle variation of the order of  $0.1^\circ$  may be obtained by taking tapings in a step of 10 turns for a design value of induced voltage of 1 volt per turn.

It may be proved that the phase shifter works equally well both for balanced and unbalanced load currents by applying a similar logic as reported in reference<sup>[9]</sup>. Thyristor controlled on-load tap-changer (OLTC)<sup>[10,11]</sup> for changing the tapings of the phase shifter may be used.

**Implementation of the scheme:** Load flow studies of many practical power system show that the  $\angle \Phi$  seldom exceeds  $10^\circ$  between any two buses, provided the transmission line length between them is not more than a few hundred kilometers. This is verified from the IEEE 30-bus load flow data<sup>[12]</sup>. Implementation of the scheme is explained with a representative power system having the following data. Referring Fig. 2;

The total load on bus1=1p.u. at unity power factor.

$|V_1|=|V_2|=1$  p.u. Received power through the distribution line DL is: P=0.5 p.u. Q=0 p.u.

Two cases are considered:

- \* Phase shifter equipped with on-load tap changing (OLTC) and  $X=0.1$  p.u.  $X_c=0$ : External series reactance is not used and the range of phase angle difference is assumed to be  $-12^\circ \leq \Phi \leq -4^\circ$ .

From equation (4);  $\delta=2.86^\circ$ ; Therefore,

$$6.86^\circ \leq \beta \leq 14.86^\circ \quad (11)$$

From equation (3);  $k=|V_3|/|V_1|=1.001 \cong 1$ ; As discussed earlier it is not difficult to obtain a phase angle variation in steps of  $0.1^\circ$  in this range of  $\beta$  as given in equation (11). Thyristor controlled OLTC may do the control function efficiently with the help of a feedback signal of the real power flow P.

\* Phase shifter having fixed tap setting: To reduce the cost and complexity of operation an off-load tap changer with fixed tap settings during on-load operation is preferred. Proper precaution should be taken to avoid wide variation in P for small changes in  $\Phi$  with fixed tap settings.

Additional power flow from bus2 to bus1 is most essential during peak hours only. From the load flow data of the peak period, the value of  $\Phi$  may be estimated and it is assumed to be  $-10^\circ$  for the present analysis. Equation (5) suggests that a higher value of X reduces the variation in the value in  $\beta$  for small changes in  $\Phi$ . By connecting external series reactor of 0.4 p.u., the total reactance X becomes 0.5 p.u. From equation (4),  $\delta=14.04^\circ \cong 14^\circ$ ;

Therefore,  $\beta=24^\circ$  and from equation (3),  $k=|V_3|/|V_1|=1.03$ . Three percent increase in voltage at bus3 does not create any insulation problem. The ratio  $|V_3|/|V_1|$  is same as  $|V_{a0}|/|V_{a1}|$ . From equation (8),  $\alpha_2=11.2^\circ$  for  $k=1.03$  and  $\alpha_1=12.8^\circ$ .

It may be concluded that for fixed tap settings of  $\alpha_1=12.8^\circ$  and  $\alpha_2=11.2^\circ$ , the real and reactive power flow remain constant at 0.5 p.u. and 0 p.u., respectively for a constant value of  $\Phi=-10^\circ$ . But with constant phase shift angle of  $24^\circ$ , if  $\Phi$  changes by a small angle of  $\pm 2^\circ$ , the changed values of P and Q becomes; P=0.428 p.u. Q=0.015 p.u. for  $\Phi=-12^\circ$  and P=0.568 p.u. Q=-0.02 p.u. for  $\Phi=-8^\circ$ .

Using equations (4), (5), (8) and (9) computer simulation was carried out to obtain values of  $\alpha_1$ ,  $\alpha_2$  and k for varying values of P and  $\Phi$  over a wide range. Ranges of P,  $\Phi$  and  $X_e$  values used are 0.2 to 0.6 pu,  $\pm 4^\circ$  to  $\pm 12^\circ$  and 0 to 0.4 pu, respectively. Higher value of external reactance reduces the change in P and Q to a minimum for fixed tap settings.

Connecting three single-phase 250V, 10A and 50Hz variable autotransformers in delta, laboratory testing was carried out to demonstrate the feasibility of the operation of the phase shifter as reported in<sup>[9]</sup>. The output was tapped from a second set of brushes that could be fixed at any position of the windings. The test result exactly replicates to those given in<sup>[9]</sup> and showed that the output could always be adjusted to get the desired phase difference in the range of 0 to  $30^\circ$  between the input and output voltages. The output to input voltage ratio could also be adjusted independently from 1.0 to 1.05.

Though the number of tapings in the autotransformer is large, but the phase shifter will be definitely cheaper in comparison to the back-to-back dc or UPFC alternative.

## CONCLUSION

The phase angle difference between voltages of any two buses of a big power system depends upon the

operating and loading conditions of the power system. Sharing a common distribution load from these phase shifted sources needs the operation of a phase shifter, having adjustable phase angle and output voltage, connected between these two busbars. A 3-phase tapped autotransformer connected in delta having input and output terminals at two different tap settings may work as a phase shifter. By suitably altering the tapings, the phase shift angle and the output voltage magnitude may be controlled independently for controlling the real and reactive power flow. The analysis and control strategy of the static phase shifter both with on-load tap changing facility and with fixed tap setting have been presented. Experimental verification of the phase shifter operation in a laboratory model was carried out successfully.

## REFERENCES

1. Hingorani, N.G. and L. Gyugyi, 1999. Understanding FACTS. IEEE Press, New York.
2. Padiyar, K.R., 1993. HVDC Power Transmission System. Wiley Eastern, New Delhi.
3. Gyugyi, L., 1992. A unified power flow control concept for flexible AC transmission systems. IEEE Fifth Intl. Conf. AC and DC Power Transmission, London, pp: 19-26.
4. Papie, I., 1997. Basic control of unified power flow controller. IEEE Trans. Power Systems, 12: 4.
5. Etis, A., 1991. Enhancement of first swing stability using a high speed phase shifter. IEEE Trans. Power Systems, 6: 3.
6. Iravani, M.R. and D. Maratukulam, 1994. Review of semiconductor-controlled (static) phase shifters for power system applications. IEEE/PES Winter Meeting, Paper no. 94 WM 182-6 PWRS.
7. Mathur, R.M. and R.S. Basati, 1981. A thyristor-controlled static phase shifter for AC power transmission. IEEE PAS, 100: 5.
8. Grainger, J.J. and W.D. Stevenson, 1994. Power System Analysis. McGraw-Hill. Singapore.
9. Basu, K.P. and S.P. Patra, 1970. Application of variable auto-transformer as phase shifter. J. Institution of Engineers (India), EL, 51: 22-27.
10. Arrillaga, J. and R.M. Duke, 1980. A static alternative to transformer on load tap changers. IEEE Pas, 3: 1.
11. Guth, G. *et al.*, 1981. Static thyristor-controlled regulating transformer for AC transmission. IEEE Intl. Conf. Thyristor and Variable Static Equipment for AC and DC Transmission, No. 205, London.
12. Saadat, H., 2004. Power System Analysis. Second Edn. McGraw-Hill, Singapore.