

## Lisrel Analysis of Factors for Empowering Producers to Abolish Livelihood Poverty through Optimizing Agricultural Water Resources Management

<sup>1</sup>Fatemeh Panahi and <sup>2</sup>Iraj Malekmohammadi

<sup>1</sup>Dezful Branch, Islamic Azad University, Agriculture College, Dezful, Iran

<sup>2</sup>Tehran University, Karaj, Iran

---

**Abstract: Problem statement:** Most of the projected increase in global population will take place in third world countries that already suffer from water, food, and health problems. Irrigation in developing countries tends to be stereotyped as equity reducing, in competition with other uses for scarce water resources. Agricultural intensification through the practice of irrigation as a strategy for poverty reduction is examined. Water users were surveyed in order to explore their perception about the factors influencing the optimizing water consumption in agricultural sectors in Iran. This study looks into water-poverty interfaces as well as into approaches to and tools of, managing water in such a manner that water sector activities can contribute to alleviation of poverty. In addition, this study aims to empower water users with information on agricultural wastewater. **Approach:** The methodology used in this study involved a combination of descriptive and quantitative research. The total population was 350 producers in six provinces in Iran. **Results:** Based on the perception of the respondents and ordinal factor analysis, the factors were categorized into four group's namely technical and practical, recognition and managing water equipment and constructive ordered by the magnitude of their impact. The total variance explained by these 4 factors is 54.27% as effective mechanisms in optimizing agricultural water resources management. Structural equation model is expected to be useful for designing targeted optimizing agricultural water resources management and poverty alleviation strategies that also enhance agricultural-productivity growth. **Conclusion/Recommendations:** Where there is equity in resource distribution, the impact of improved water management on agricultural productivity growth has been more poverty reducing. Using water better means improving the productivity of agricultural water in both irrigated and rainfed systems, through multiple-use water system, integrated water resources planning, and targeted research.

**Key words:** Empowering producers, abolish poverty, water management, Waste water management, rural livelihood, agricultural water

---

### INTRODUCTION

UNDP (2004) pointed out agriculture is now and will continue to be a key source of livelihood for low-income countries and the poor who live there. In these countries, 80% of export earnings come from the agricultural sector, which uses more water than any other enterprise. As stated by Takashi (2001), agriculture is the major economic sector in most developing countries.

Water has been predicted to be the oil of the twenty-first century, meaning that successful water management will be the key to future economic growth and social wealth in both developed and developing countries (Clothier, 2000).

The World Bank showed that Agricultural Water Management (AWM) is not a goal in itself but part of a

process of resource management that provides critical input to agricultural production and farmer incomes (Vinod, 2006).

Iran contains both arid and semiarid regions with an annual average precipitation of 250 mm, which is less than one-third of the global average. Currently, total water consumption is approximately 88.5  $\text{bm}^3$  year, of which more than 92-94% is used in agriculture and less than 7% is allocated to urban and industrial consumption. In total, 82.5  $\text{bm}^3$  of water is utilized for irrigation on 7.8 million ha of cultivated land.

The irrigation potential in Iran is estimated at 37 million ha, with only 7.8 million ha currently receiving irrigation water, representing 21% of the potential. Of the total arable land, about one-third is irrigated by traditional systems. Keshavarz *et al.* (2003) observed

that overall irrigation efficiency in Iran ranges from 33-37%, lower than the average for both developing countries (45%) and developed countries (60%).

As Malakmohammadi (2009) stated, in the most vulnerable areas of the world such as Asia and Pacific Region that accounts for 57% of the world's population (nearly 3.2 billion), about half of that population will be younger than 25 in 2010, more than 80% of the world's smallholder farmers and 73% of the total farming households live in, two-thirds of the world's hungry and poor are found here, 800 million people who are poor and 500 million of them who are malnourished.

Iran's population is approximately 70.495 million, of whom 31.36% live in rural regions, 23.4% of the total population is classified as active in the agricultural sector and this percentage is equivalent to 3.611 million people of the 23.469 million active in the economic sector (SCI, 2007). It has been estimated that Iran's population will reach 90 million by the year 2020 (Raghfar, 2007). Such an increase would require 172 million tons of agricultural production from irrigated land (Keshavarz *et al.*, 2003).

In 2004, the poverty line rose to 29% in rural states and to 28% in urban areas. Thus, the proportion of people classified as poor has increased since 2004 (Raghfar, 2007).

More than 90% of the renewable water in the country is used for agriculture, but the sector still cannot produce enough to meet the demands of the population. Currently, agricultural products from irrigated farming total 56 million tons.

The amount of water used for irrigated agriculture is 83  $\text{bm}^3$ , so water productivity is 0.7  $\text{kg m}^{-3}$ . To supply adequate food in 2020, agricultural production will have to increase to 160 million tons. So by the year 2020, water productivity will have to increase to 1.6  $\text{kg m}^{-3}$ . Therefore, it is important to focus on using water efficiently through improved irrigation and water management.

Iranian agriculture has suffered from inefficient resource management by actors within the sector, rather than by limited natural resources. Thus, it is essential to give more consideration to human resources in the agricultural sector.

Since farmers and water users are the primary active human resources in the agricultural sector, it is necessary to increase their competence in order to improve the efficiency and productivity of farming. Today, this is becoming increasingly important because of the competitiveness within the sector.

Ommani (2008) referred to Evenson as he said agricultural extension and education will impact the economics and sustainability of agriculture by

providing information to induce farmers' awareness and knowledge through testing and experimentation, farmers' adoption of new technology or practices and changes in farmers' productivity.

Malakmohammadi (2009) pointed out, agricultural extension is a public service for Human Resource Development (HRD) in the agricultural sector. Although extension is not the magic wand that will change agriculture overnight. Nonetheless, extension will impact human capital development through agricultural literacy, thus enhancing economic growth (Malakmohammadi, 2009).

**Prior research:** Ward *et al.* (2005) showed that agriculture in most locations generates the lowest value added per unit of water compared to other water-using sectors. Within the agricultural sector, however, there are numerous ways to improve the return on investments in water. Higher return on water investments will boost incomes for farmer.

FAO (2003) reveal that for improving irrigation management, efforts are focused on the empowerment of water users associations and their involvement in resource management.

Rahaman *et al.* (2004) and Biswas *et al.* (2003) assert that to be effective, water management must take a holistic approach, linking social and economic development with the protection of natural ecosystems.

As stated by Shen and Varis (2000), the water resource management crisis is the result of poor management rather than of modern technologies. Technology-oriented management should be balanced with human-oriented management (Ahmad, 2003).

Akpabio *et al.* (2007) pointed out that equitable resource allocation, efficient and balanced resource use, participation of stakeholders in decision making and recognition of linkages and interactions among human and physical systems are key principles in integrated water resource management.

Giordano (2007) believes that the increasing pressure on agricultural water use comes at a time when rural poverty reduction and national food security are major national goals.

Hussain *et al.* (2006) showed that negative social and environmental consequences often hurt the poor more than the non poor because the poor lack political power and the financial resources to avoid the potentially adverse impacts of irrigation, from physical displacements to health risks and land degradation.

Akpabio *et al.* (2007) reported that irrigation can increase the yields of most crops. Furthermore, irrigation leads to less risky and more continuous levels of rural employment and income. Irrigated as compared

to rain-fed agriculture is conducive to higher cropping intensities that improve yields, allowing the cultivation of higher-value crops and the use of sophisticated cultivation techniques (Smith, 2004).

Water resources development and management play a fundamental role in sustainable growth and poverty reduction (Molden, 2007; Hussain and Hanjra, 2003; 2004; Varma *et al.*, 2006; Rijsberman *et al.*, 2006; Rijsberman, 2003).

Hussain *et al.* (2004) assert that there are five key dimensions of the relationship between access to good agricultural water and socioeconomic improvement in rural areas: production, income, consumption, employment, vulnerability, food security and overall welfare. Hussain (2004) maintains that irrigation can influence poverty through three pathways: (a) micro-pathway; (b) meso-pathway and (c) macro-pathway.

Carriger (2005) showed that research has confirmed that irrigation development does reduce poverty.

## MATERIALS AND METHODS

The methodology used in this study involved a combination of descriptive and quantitative research. The population of this study included producers, (N = 220000) in selected six provinces, of which 350 producers was selected. Research based on the Cochran formula and using stratified random sampling and questionnaires. Face validity was established by a panel of experts consisting of faculty members and graduate students at Tehran University, Tarbiat Modares University and Islamic Azad University, Iran. A pilot test was conducted with 30 producers. Questionnaire reliability was estimated by calculating Alfa Cronbach and Compose Reliability methods by Spss and Lisrel software. Reliability for the overall instrument was estimated at 0.85 and 0.68 respectively.

## RESULTS

The results of descriptive statistics show that most of the producers in the research were the men (98.3%)

who are the annual income rate and income from agriculture were 131700 and 102100 thousand Rials, respectively.

The average of annual expenses for the producer's family is 106600 thousand Rials and the expense for more than 30% of the study population is less than 50 million Rials.

It was reported that slightly more than 30% of producers had primary school degree whose maximum level of literacy was bachelor.

Over 80% of the producer families holding own land and only 18.9% having agricultural land and laborer.

Amount to 56% of the producers possess less than 5 hectares of irrigated farming land and 69.4% having below 3 tracts of irrigated land.

Deep-well is the irrigation resource for most of the research answerers and only 28% of them using two or more water resources for irrigate. More than 70% of the producers using canal irrigation and only 1.7% using rain method of irrigation in addition.

The average share of water for each producer is 2.5 units. 68% of the producers owning the water resource individually and for most of them, the resource is located in the farm field or around.

The capability of producers in utilizing the mechanism of agriculture water resources management was very low and most of them believe that the efficiency of these mechanisms is very high.

From the producer's point of view, acting according to the extension advices, Adjusting irrigation canal deficiencies and leveling land as the principles of water resources management, has systematic priority in resources, transferring and the farm.

According Table 1, from the viewpoint of the producers, restoring and renovation of canals has the initial priority in agriculture water management activities done by the government.

From the viewpoint of the producers, visiting the agent in the service centers in order to perform extension programs in agriculture water management has the initial priority (Table 2).

Table 1: Ranks of activities done by the government to manage agriculture water resources

Factors	Median	SD	CV	Rank
Restoring and renovation of canals	3	1.348	0.449	1
Digging new wells	2	1.578	0.789	2
Repairing old wells	2	1.714	0.857	3
Restoring and renovation of springs and related rivers	1	1.443	1.443	4
Constructing deviation dams and the related canals on rivers	1	1.521	1.521	5
Dredging aqueduct	1	1.522	1.522	6
Pool reserves for agriculture water purposes	1	1.565	1.565	7

Table 2: Ranks of extension services in order to cure the agriculture water management

Factors	Median	SD	CV	Rank
Visiting the agent in the service center	2	1.501	0.750	1
Scientific tour on visiting irrigation methods	1	1.383	1.383	2
To study magazines	1	1.451	1.451	3
Participating in extension courses	1	1.463	1.463	4
Visiting the agent in the village	1	1.472	1.472	5

Table 3: The quantities of standard parameters in factor analysis of obstacle in utilizing optimizing agriculture water resources management

Latent variable	Observed variables	SS	R <sup>2</sup>	t	E	Variance by factor
Economical and finance	High cost sprinkler irrigation system (installation and maintenance)	0.75	0.52	14.15	0.053	13.400
	High cost of converting traditional canals	0.77	0.61	15.59	0.055	
	Government weak policies	0.78	0.58	11.58	0.048	
	Shortages in the credits	0.79	0.64	10.22	0.066	
	Shortage in assisting services	0.61	0.37	11.87	0.055	
	Lack of insurance for irrigation systems	0.62	0.39	8.750	0.070	
	Shortage in irrigation equipment	0.61	0.31	10.79	0.061	
	Subside allocation of water in agriculture	0.58	0.33	15.06	0.057	
Planning	Effects of digging deep wells on dryness semi deep wells	0.64	0.34	10.15	0.070	11.890
	No drainage system usage	0.76	0.62	8.750	0.070	
	No usage of agriculture water drainage	0.73	0.56	13.03	0.074	
	Inconsistency between the number of wells and field area	0.64	0.33	10.03	0.069	
Extension and education	Salinity land	0.71	0.36	10.46	0.078	9.360
	Unawareness on low benefit in traditional methods	0.70	0.49	11.00	0.490	
	No acceptance of modern irrigation systems	0.71	0.51	11.90	0.110	
	Unawareness of modern irrigation technologies	0.79	0.63	12.94	0.110	
Natural	Lack of irrigation specialists expert	0.64	0.41	10.75	0.085	5.900
	Scattering of land tracts	0.51	0.56	3.340	0.460	
	Common water resource	0.60	0.24	8.360	0.120	
Total						40.56%

By using Lisrel 8.5 software, ordinal factor analysis have been done to know the obstacle factors in optimizing agriculture water resources management and consequently abolish poverty and it was clear by using the statistics on constructive equations that, the best analysis is the factor analysis having 4 factor and Logit function. As it is observed in the Table 3, finance and economic problems, planning, extension and education and natural are the four grades in the correct management of agriculture water resources.

The total variance explained by these four factors is 40.56% in an incorrect management of agriculture water resources and the rest of variance explained by the other factors not included in the research (Table 3).

Model fit range from acceptable (RMSEA) to weak ( $X^2/df$  ratio and p- value) to good (CFI, GFI, AGFI and NFI (Table 4 and Fig. 1).

Table 5 shows the grouping, arrived at by using ordinal factor analysis in SEM of the factors into four latent variables, namely technical and practical, recognition, managing water equipment and constructive.

Table 4: Suitability indicators in factor analysis obstacle factors in utilizing best management of agriculture water usage

Goodness of fit test	Amount
Normal theory weighted least squares chi-square	384.61
P-value	0.03
Degrees of freedom	142.00
Root Mean Square Error of Approximation (RMSEA)	0.07
Comparative Fit Index (CFI)	0.96
Normal Fit Index (NFI)	0.94
Goodness of Fit Index (GFI)	0.90
Adjusted Goodness of Fit Index (AGFI)	0.86

The basic idea of factor analysis is to find a set of latent variables that contain the same information. The classical factor analysis assumes that both observed and latent variables are continuous variables but, in practice, the observed variables are often ordinal.

The total variance explained by these four factors is 54.27% as effective mechanisms in optimizing agricultural water resources management and the rest of variance explained by the other factors not included in the research.

Spearman coefficient was employed for measurement of relationships between the ability of producers in optimizing agriculture water resources

management and factors which influencing the empowerment in water resources management. Table 6 displays the results which show that there were relationship between ability of respondents about optimizing agriculture water resources management and the total incoming, education level, size of the farm, share of water resource, technical knowledge, attitude on management of water resources, extension programs perform in agriculture water management and rate of cooperation between the producers and related organizations in water management. The findings also indicated that there was no relationship between the

number of irrigated land tracts and length of farm water canal.

The quantities of standard parameter for each factor, shows their pressure on the variance that indicating the amount of  $t > 2$  and their share in the measurement of variance Table 7 and 8).

The bivariate correlation between the latent variable poverty and agriculture water management would be  $SS = 0.49$ . The Adjusted R Square ( $R^2$ ) explained by these factors is 46% and the rest of  $R^2$  explained by the other factors not included in the research (Table 9).

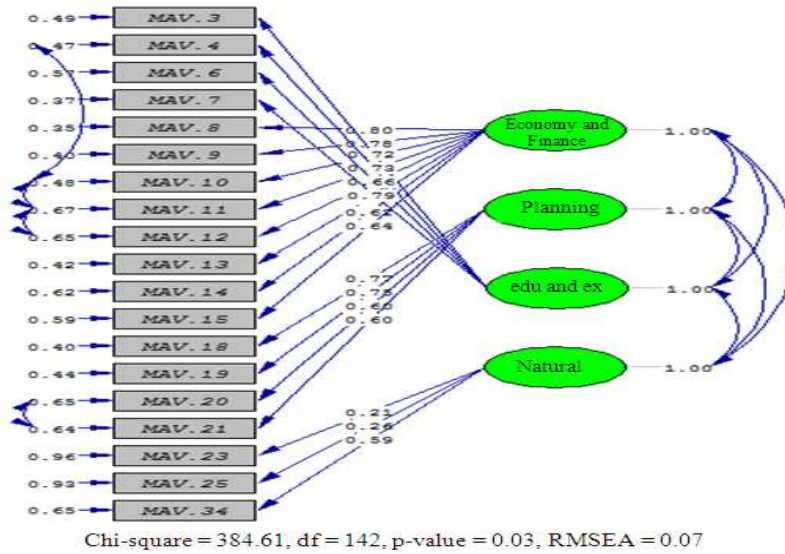

Fig. 1: X model of obstacle factors in utilizing best management of agriculture water usage

Table 5: Factor analysis of effective mechanism in empowering producers in agriculture water resources management

Latent variable	Observed variables	Variance by factor
Technical and practical Recognition	Conservation irrigating systems, Installation of modern irrigation systems, using of discharge measurement equipment, acting according to the extension advices, canal lining	15.94
Managing water equipment	Plan consumption water use equal to irrigation level, Cultivating low and high water plants simultaneous, familiarity with assigning water	14.77
Constructive	Unawareness of traditional methods low efficiency on low benefit in traditional methods, low acceptance of modern systems, unawareness of modern irrigation technologies, lack of irrigation specialists expert	14.27
Total	Sattering of land tract, common water resources	9.41
		54.27%

Table 6: Correlation measures employment between research factors and ability of producer in agriculture water resources management

Factors	r	Sig
Education level	0.123*	22.000
Total incoming	0.162*	0.002
Number of irrigated land tracts	0.132	0.081
Size of the farm	0.126*	0.019
Share of water resource	0.117*	0.029
Length of farm water canal	0.082	0.126
Technical knowledge	0.326**	0.000
Attitude on management of water resources	0.281**	0.000
Agriculture water management activities done by the government	0.289**	0.000
Extension programs perform in agriculture water management	0.640**	0.000
Rate of cooperation between the producers and related organizations in water management	0.194**	0.000

\*\* : p<0.01, \* : p<0.05

Table 7: The quantities of standard parameters for X model (the wealth of producers and also water resource management)

Latent variable	Observed variables	SS	R <sup>2</sup>	t	E
Producers	Size of garden	0.63	0.39	11.77	0.590
	Size of farm	0.80	0.64	17.36	1.640
Property and wealth	Dry farming land under cultivation	0.72	0.52	14.51	0.310
	Number of irrigating resources	0.60	0.36	12.25	0.090
	Share of water resource	0.42	0.18	8.34	0.140
Agriculture Water Management	Capability of producers in managing agricultural water	0.60	0.36	8.20	0.048
	The producers viewpoint in the affairs of agriculture water resources management	0.35	0.12	4.97	0.059
	Obstacles in managing agriculture water	0.60	0.36	8.00	0.060

Table 8: The quantities of standard parameters for model (poverty)

Latent variable	Observed variables	SS	R <sup>2</sup>	t	E
Poverty	Income level	0.95	0.89	3.96	0.081
	Life expenses	0.84	0.73	21.95	0.480

Table 9: The quantities of standard parameters for model (poverty)

Path	SS	R <sup>2</sup>	t	E
From agriculture water resources management to poverty X <sub>2</sub> → X <sub>1</sub>	0.49	0.46	7.31	0.063
From the property and wealth of producers to poverty X <sub>3</sub> → X <sub>1</sub>	0.44	0.46	9.36	0.052

Table 10: The direct, indirect and total effect in structural model

Path	Direct	Indirect	Total
From agriculture water resources management to poverty X <sub>2</sub> → X <sub>1</sub>	0.49	-	0.49
From the property and wealth of producers to poverty X <sub>3</sub> → X <sub>1</sub>	0.44	-	0.44

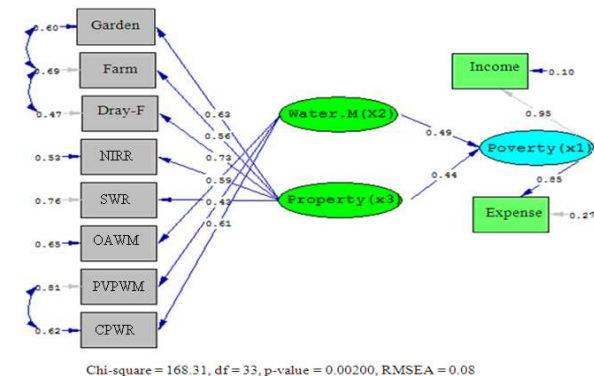

Chi-square = 168.31, df = 33, p-value = 0.00200, RMSEA = 0.08

Fig. 2: Structural model of abolish poverty

By using Structural Equation Model (SEM) clear that the most direct and total effect related to agriculture water resources managements with SS = 0.49 and this factors are the most effect in explaining the model (Table 10).

Parameters indicated an acceptable to good model fit (Table 11 and Fig. 2).

**Structural equations:**

$$\begin{aligned}
 \text{Poverty}(X_1) = & 0.49 \text{ water. M } (X_2) + 0.44 * \text{property } (X_3) \text{ Error var.} = 0.52, R^2 = 0.46 \\
 & (0.063) \quad (0.052) \quad (0.067) \\
 & 7.31 \quad 9.36 \quad 7.83
 \end{aligned}$$

Table 11: Suitability indicators in structural poverty alleviation model

Goodness of fit test	Amount
Normal theory weighted least squares chi-square	163.310
P-value	0.020
Degrees of freedom	33.000
Root Mean Square Error of Approximation (RMSEA)	0.080
Comparative Fit Index (CFI)	0.890
Normal Fit Index (NFI)	0.860
Goodness of Fit Index (GFI)	0.910
Adjusted Goodness of Fit Index (AGFI)	0.850

**DISCUSSION**

As the ordinal factor analysis showed, the factors were categorized into four groups, namely finance and economic problems, planning, extension and education and natural ordered by the magnitude of their impact.

The findings show that economical and finance factors are the most important, a result that echoes of (Vinod, 2006; Ward *et al.*, 2005; Varma *et al.*, 2006).

Planning factors are always potentially playing an important role in the optimizing agriculture water resource management. Rijsberrman *et al.* (2006) believe that in order to integrated water resources management, planning is the principle factors.

The results of ordinal factor analysis show that technical and practical factors are the most important for empowering producers in agricultural water

resources management, a result that echoes of Smith (2004) pointed out that water management can be greatly improved if the capacities, skills and perspectives of water users are promoted.

Structural equation model is expected to be useful for designing targeted optimizing agricultural water resources management and poverty alleviation strategies that also clear that in alleviation of poverty the most direct and total efficiency related to agriculture water resources managements. Biswas *et al.* (2003) believe that Poverty is a complex issue, which must be understood in a holistic manner. Low and variable income is certainly a key element, but it is far from enough to portray poverty (Ahmad, 2003; Hussain and Hanjra, 2003; 2004; Rijsberman, 2003; Hussain, 2004).

### CONCLUSION

Access to water in equitable manner and the improved management of water are imperative to sustainable development, poverty alleviation and biodiversity preservation.

Water and poverty interface in many different ways. Sustainable management (i.e., development, allocation and utilization) of water resources is therefore a process-element of sustainable human development.

It is argued that there is not a single silver bullet to reduce poverty though water resources development or management. The best chance for lasting and sustainable impact on poverty is likely to be achieved through a combination of sustainable water resources development, combined with the development of appropriate pro-poor institutions and technologies.

Finally we argue that the antipoverty impact of irrigation water can, therefore, be intensified through triggering a set of board and targeted interventions, simultaneously.

### REFERENCES

Ahmad, Q.K., 2003. Towards poverty alleviation: The water sector perspectives. *Int. J. Water Resour. Dev.*, 18: 263-277. <http://www.ingentaconnect.com/content/routledg/cijw/2003/00000019/00000002/art00014>

Akpabio, E.A., N.M. Watson, U.E. Ire and I.E. Ukpogon, 2007. Integrated water resources management in the cross river basin, Nigeria. *Int. J. Water Resour. Dev.*, 23: 691-708. DOI: 10.1080/07900620701488612

Biswas, A.K., A. Shady, J. Lundqvist and K. Takahashi, 2003. Workshop 3 (synthesis): Water, poverty alleviation and social programs. *Water J. Sci. Technol. Abst.*, 47: 129-132. <http://www.ncbi.nlm.nih.gov/pubmed/12731781>

Carriger, S., 2005. Reducing Poverty through Integrated Management of Ground Water and Surface Water. An Opportunity to Improve Equity, Efficiency and Sustainability in Irrigated Areas. 1st Edn., Water Policy Briefing, IWMI, 13, Colombo, Sri Lanka, pp: 8.

Clothier, B.E., 2000. Globalization of water management. *Agric. Water Manage.*, 45: 215-216.

FAO., 2003. Sustainable water resource management for food security in the Near East region. Proceeding of the High-Level Technical Workshop on Regional Programs for Food Security in the Near East: Toward Sustainable Food Security and Poverty Alleviation, Oct. 8-9, FAO, Jeddah, pp: 12. <http://www.Fao.org.ir/>

Giordano, M., 2007. Agricultural water policy in China: Challenges. Issues and options. *J. Water Policy Abst.*, 9: 1-9. <http://cat.inist.fr/?aModele=afficheN&cpsid=18454786>

Hussain, I. and M.A. Hanjra, 2003. Does irrigation water matter for rural poverty alleviation? Evidence from South and South-East Asia. *J. Water Policy Abst.*, 5: 429-442. <http://cat.inist.fr/?aModele=afficheN&cpsid=15342068>

Hussain, I. and M.A. Hanjra, 2004. Irrigation and poverty alleviation: Review of the Empirical evidence. *Irrigat. Drain.*, 53: 1-15. DOI: 10.1002/ird.114

Hussain, I., 2004. Assessing impacts of irrigation on poverty: Approaches, methods, case studies and lessons. Proceeding of the Workshop on International Water Management Institute (IWMI-BOKU-Siebersdorf-EARO-Arbamintch University Collaborative Study on the Impact of Irrigation Development on Poverty and Environment, Apr. 26-30, Ethiopia, pp: 1-9. [http://www.iwmi.cgiar.org/propoor/files/ADB\\_Project/Research\\_Papers/poverty%20paper%20-ethiopia.pdf](http://www.iwmi.cgiar.org/propoor/files/ADB_Project/Research_Papers/poverty%20paper%20-ethiopia.pdf)

Hussain, I., D. Wijerathna, S.S. Arif, Murtiningrum, A. Mawarni, and Suparmi, 2006. Irrigation, productivity and poverty linkages in irrigation systems in Java, Indonesia. *Water Resour. Manage.*, 20: 313-36. DOI: 10.1007/s11269-006-0079-z

- Hussain, I., M. Giordon and M.A. Hanjra, 2004. Agriculture water and poverty linkages: Care studies on large and small systems. [http://www.Iwmi.cgiar.org/propoor/files/ADB\\_PROJECT/Researchpapers/Agricultural\\_water\\_poverty\\_linkages.PDF](http://www.Iwmi.cgiar.org/propoor/files/ADB_PROJECT/Researchpapers/Agricultural_water_poverty_linkages.PDF)
- Keshavarz, A., N. Heydari and S. Ashrafi, 2003. Management of agricultural water consumption, drought and supply of water for future demands. Proceeding of 7th International Conference on the Development of Dry Land, Sept. 14-17, DDL Press, Tehran, Iran, pp: 42-48.
- MalakMohammadi, I., 2009. Toward clean sustainable development to prevent the first food world war changing. authorities-public extension to literalized- partnership extension system. *Am. J. Agric. Biol. Sci.*, 4: 49-62. <http://www.scipub.org/fulltext/AJAB/AJAB4149-62.pdf>
- Molden, D., M. Burton and M.G. Bos, 2007. Performance assessment, irrigation service delivery and poverty reduction: Benefits of improved system management. *Irrigat. Drain.* 56: 307-320. DOI: 10.1002/ird.313
- Ommani, A.R., 2008. Identifying extension mechanisms for supporting Sustainable Water Resource Management (SWRM) in agriculture in Khuzestan, province. Ph.D. Thesis, Islamic Azad University, Science and Research Branch, Iran.
- Raghfar, H., 2007. Poverty in Iran 1989-2007. *Soc. Welfare Q.*, 6: 57-71.
- Rahaman, M.M., O. Varis and T. Kajander, 2004. EU water framework directive Vs integrated water resources management: The seven mismatches. *Int. J. Water Resour. Dev.*, 20: 565-575. DOI: 10.1080/07900620412331319199
- Rijsberman, F., 2003. Can development of water resources reduce poverty? *J. Water Policy Abst.*, 5: 399-412. <http://cat.inist.fr/?aModele=afficheN&cpsidt=15342066>
- Rijsberman, F., N. Manning and S.D. Silva, 2006. Baseline document increasing green and blue water productivity to balance water for food and environment. Proceeding of the 4th World Water Forum Water, Food and Environment, Jan. 18-18, IWMI Press, pp: 1-6.
- Shen, D. and O. Varis, 2000. World water vision: Balancing thoughts after Hague. *Ambio*, 34: 523-525. <http://www.jstor.org/stable/4315087>
- Smith, L.D., 2004. Assessment of the contribution of irrigation to poverty reduction and sustainable livelihoods. *Int. J. Water Resour. Dev.*, 20: 243-257. DOI: 10.1080/0790062042000206084
- Statistics Center Iran (SCI), 2007. Population and housing census, national portal of statistics. <http://www.amar.org.ir/portal/faces/public/census85/census85.natayej>
- Takashi, K., 2001. Globalization and management of water resources: Development opportunities and constraints of diversified developing countries. *Int. J. Water Resour. Dev.*, 17: 481-487. DOI: 10.1080/07900620120094118
- UNDP., 2004. Water governance for poverty reduction. Key Issues and the UNDP Response to Millennium Development Goals. <http://www.undp.org/water>
- Varma, S., S. Verma and R.E. Namara, 2006. Promoting Micro-Irrigation Technologies that Reduce Poverty. 1st Edn., Water Policy Briefing, 23, IWMI., Colombo, Sri Lanka, pp: 8.
- Vinod, T., 2006. Water Management in Agriculture: Ten years of World Bank Assistance, 1994- 2004. World Bank, Washington, DC., pp: 144. <http://www.worldbank.org/ieg>
- Ward, Ch., S. Dargought, G. Minasyan and G. Gambarelli, 2005. Reneging in Agricultural Water Management: Challenges, Opportunities and Trade-Offs. Agriculture and Rural Development (ARD). The World Bank, World Bank, Washington DC., pp: 7.